



**SPECIALTY PRODUCTS
& INSULATION**

Committed To Service Excellence Worldwide!

Mechanical Insulation

Fabrication Specialties

Jacketing & Cladding

Fire Protection

Refractory Products

Acoustic Specialties

Building Insulation

HVAC Components

Marine Insulation

Safety Supplies

Tools and Equipment

www.spi-co.com



SPECIALTY PRODUCTS & INSULATION

A Global Leader and One of North America's Largest and Most Respected Insulation Distributors and Value Add Fabricators.

We Serve Commercial, Industrial, Marine and OEM markets providing Superior Solutions for Thermal, Acoustic, Fire Protection and Refractory Applications.

Count on SPI to deliver reliable product performance, exceptional customer service and absolute best value!



SPI Global Export Capability

Exporting From:

- Houston, TX
- Miami, FL
- Jacksonville, FL
- Seattle, WA
- Baltimore, MD





SPI Strengths and Stability

Established in 1982, Specialty Products & Insulation is one of the nation's largest independent Distributors and Specialty Fabricators of Mechanical and Building Insulation serving domestic and global markets. SPI provides products for Thermal (cryogenic to high temperature), Acoustic, Fire Protection and Refractory Applications.

Our team takes pride in delivering quality, industry leading products and services that represent the best value for our customers. This philosophy has helped us become a highly respected supplier to diverse market customers. Our wide range of industry proven and leading edge technology products and specialty fabrication services give us unique capabilities to provide superior solutions to customers across North America and Internationally.

SPI's highly experienced team can provide value added solutions to improve operational efficiency, increase safety and reduce installation labor. Our extensive North American network of distribution and fabrication centers provide unrivaled capability ensuring we can meet the most demanding project requirements and schedules.

Delivering what you want, when and where you need it!

Our History, Philosophy, Capabilities and Service Commitment

- SPI, founded in 1982
- Focus on the Safety of employees and customers
- Demonstrated financial responsibility and strength (for suppliers, customers and employees)
- Broad industry support via extensive network of geographically located distribution and fabrication centers
- Export services through US ports including: Houston, Miami, Jacksonville, Baltimore and Seattle
- An ongoing commitment of support, engagement and leadership of industry associations
- The experience, knowledge, professionalism and commitment of our most valuable asset, our people

This publication provides a sampling of the depth and diversity of our products and services

Safety is Job One

From day one safety has been a priority and continues with ongoing training, measurement and communication. Whether loading materials at our warehouse, fabricating value added products or delivering to the jobsite, Safety is a top priority. SPI is a regular recipient of the National Insulation Association Theodore H. Brody Distinguished Safety Award.



SPI's Insulation products are installed for: Energy Conservation, Condensation Control, Freeze Protection, Process Control, Fire Safety, Personnel Protection and Noise Control.

Commercial Construction: Mechanical & Building Thermal Insulation, Fire Protection, Acoustic Treatments and Specialties. Applications include:

- Mechanical (Plumbing and HVAC) insulation systems
- Fire protection systems for: grease, chemical fume, clothes dryer exhaust duct, SafeLite® Fixture covers, cable tray, conduit and structural fire proofing
- Acoustic specialties include Absorption Plus® panels, specialty composites to absorb and blocking sound and more
- Metal Building Insulation
- Curtain and cavity wall, Safing, parking garage, etc.



Industrial Construction: Mechanical Insulation for Cryogenic to High Temperature, Fire Protection, Refractory and Acoustic Applications.

- Process pipe, ductwork, vessel and equipment insulation
- Fire Protection for vessels, structure, cable raceways, conduits and firestops
- Acoustic specialties to absorb and block sound for a wide range of applications



Marine Industry: Products and services for commercial vessels, workboats, offshore platforms and NAVY requirements.

- Pipe, duct and tank and equipment insulation
- Hull board insulation for thermal, acoustics and fire protection
- Firestop systems
- SafeLite® ceiling recessed fixture covers



OEM Industry: Products and services include precision cut parts, laminated specialties and composites for thermal (cryogenic to high temperature), acoustic, fire protection and refractory applications.

- Appliances, Boilers, Ovens etc.
- RV Industry



Mechanical System Insulation - We provide materials from industry leading manufacturers for pipe, fittings, duct and equipment applications requiring thermal, acoustic insulation or fire protection. Products include: fiberglass, elastomeric foam, mineral wool, extruded polystyrene, polyisocyanurate and phenolic foam, cellular glass, cal-sil, perlite, aerogel, needled e-glass, high temperature blanket, endothermic mat, textiles, mass vinyl and composites.

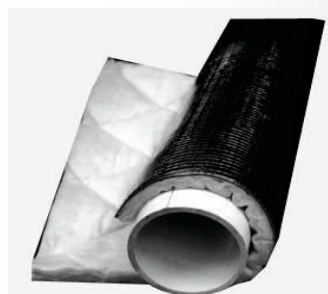
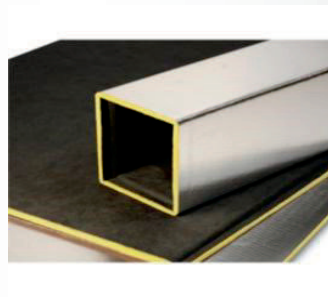
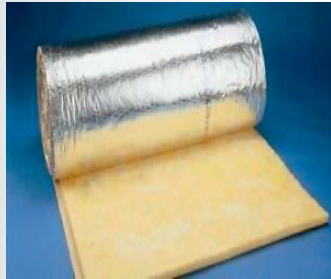
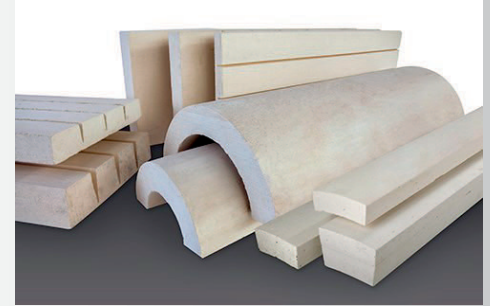

Corrosion Protection - Coatings and wraps for pipe, duct and equipment. Other CUI considerations include: insulation and jacketing selection, proper system installation, and the need for regular system inspection and maintenance.



Fabricated Products & Services - SPI partners with industry leading manufacturers of proven and leading edge technology products to provide best in class Value Add fabricated products to our customers. Products are marketed under SPI's brand and private label agreements.

Benefits of SPI Fabrication Services

- Provides fixed vs variable cost
- Reduces labor cost and personnel demands
- Reduces job site injuries and claims
- Reduces site storage damage, waste and disposal fees
- Increases site production
- Experienced fab team with refined processes and procedures perform work in a controlled environment yielding consistent high quality product
- Leverages available site labor, freeing up for other tasks
- Regional fab shops provide finished goods w/ shorter lead times
- Raw material readily available – Billets, Buns, Cores, board, batt, blanket, jacket and facing laminations
- SPI's network delivers fabricated products when & where needed

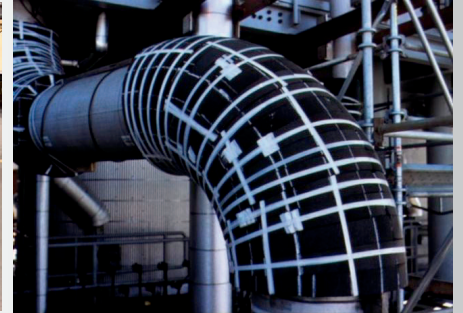

Fab Quality - We fabricate mechanical insulation products to applicable ASTM standards. We also test applicable fabricated products to ASTM standards at accredited laboratories for CODE, specification and standard compliance.



Laboratory Certified Products - SPI produces lab certified products under follow up services with UL, Intertek labs and the US Coast Guard. This experience and documented process control provides added assurance that you can depend on the quality of SPI's fabricated products.

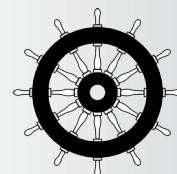

Fabricated Pipe, Duct and Equipment Insulation - SPI fabricates traditional insulation such as cellular glass, polyisocyanurate, extruded polystyrene, mineral wool, fiberglass, perlite, cal-sil and other leading edge technology products such as aerogel materials. We cut pipe insulation and apply specified jacketing materials and machine system fittings. Fabricated pipe insulation systems are produced to accommodate heat tracing and are supplied with companion metal cladding.



Fabricated Pipe Jacketing Materials - SPI provides a complete range of jacketing and cladding materials including: Metal and Plastic (roll or sheet and formed), PVC jacket, PVDC film, Proline Plus™ Jacketing, Laminates, Fabric, Mastics, Coatings and Adhesives, GRP and FRP (glass and fiber reinforced plastic).

Jacketing / cladding materials protect the insulation system and also serve as: a weather barrier, vapor retarder, condensate barrier, abuse protection and enhance the system appearance.

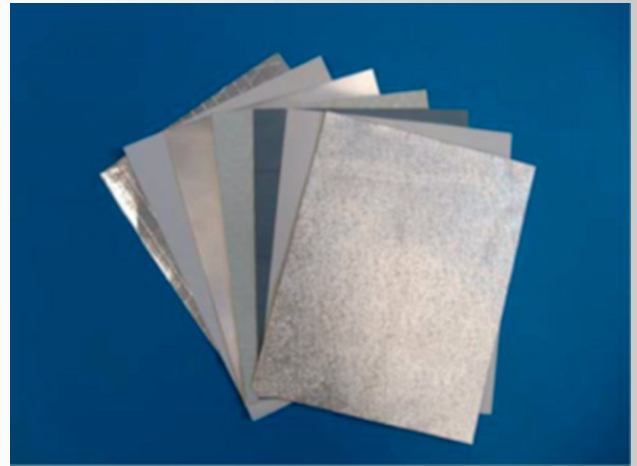

Fabricated Pipe Supports We provide custom pipe supports to meet specific application conditions in a variety of insulation materials, densities, thickness and jacketing with matching saddles to optimize system performance and longevity.



Fabricated Tank & Vessel HATS® - We Provide superior vessel head insulation systems especially critical for cryogenic applications. Our precision machined HATS improve process operating efficiencies, reduce life cycle operating and maintenance costs and provide dramatic installation labor savings. We also supply machined curved sidewall segments and companion cladding providing superior tank insulation systems.



Typical Hat Installation (provides substantial labor savings)



Tank and Vessel Curved Sidewall Segments - Providing precision machined curved insulation segments in a range of materials including: cellular glass, polyisocyanurate and extruded polystyrene foam, perlite, cal-sil and more. Segments can be supplied with square or precision beveled edges for optimal installation and thermal efficiency.



RigidFlex® Pipe & Tank Wrap - Made with leading manufacturer insulation materials laminated to industry standard FSK, ASJ and other facings. The finished roll material is used on large diameter pipe, tanks and vessels in lieu of preformed pipe and machined curved segmental Insulation. This reduces the typical long lead times associated with large diameter preformed pipe insulation. Supplied in fiberglass and mineral wool insulation at densities and thickness to meet operating temperature requirements and conditions.

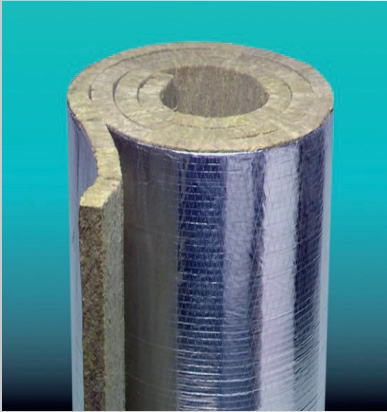

SPI Fabrication Shops - Produce a variety of products to satisfy project specification requirements



Fabricated Fitting Insulation, Concept to Prototype to Project Supply - Count on SPI's experience to deliver custom fabricated parts that fit properly to optimize thermal efficiency and savings.

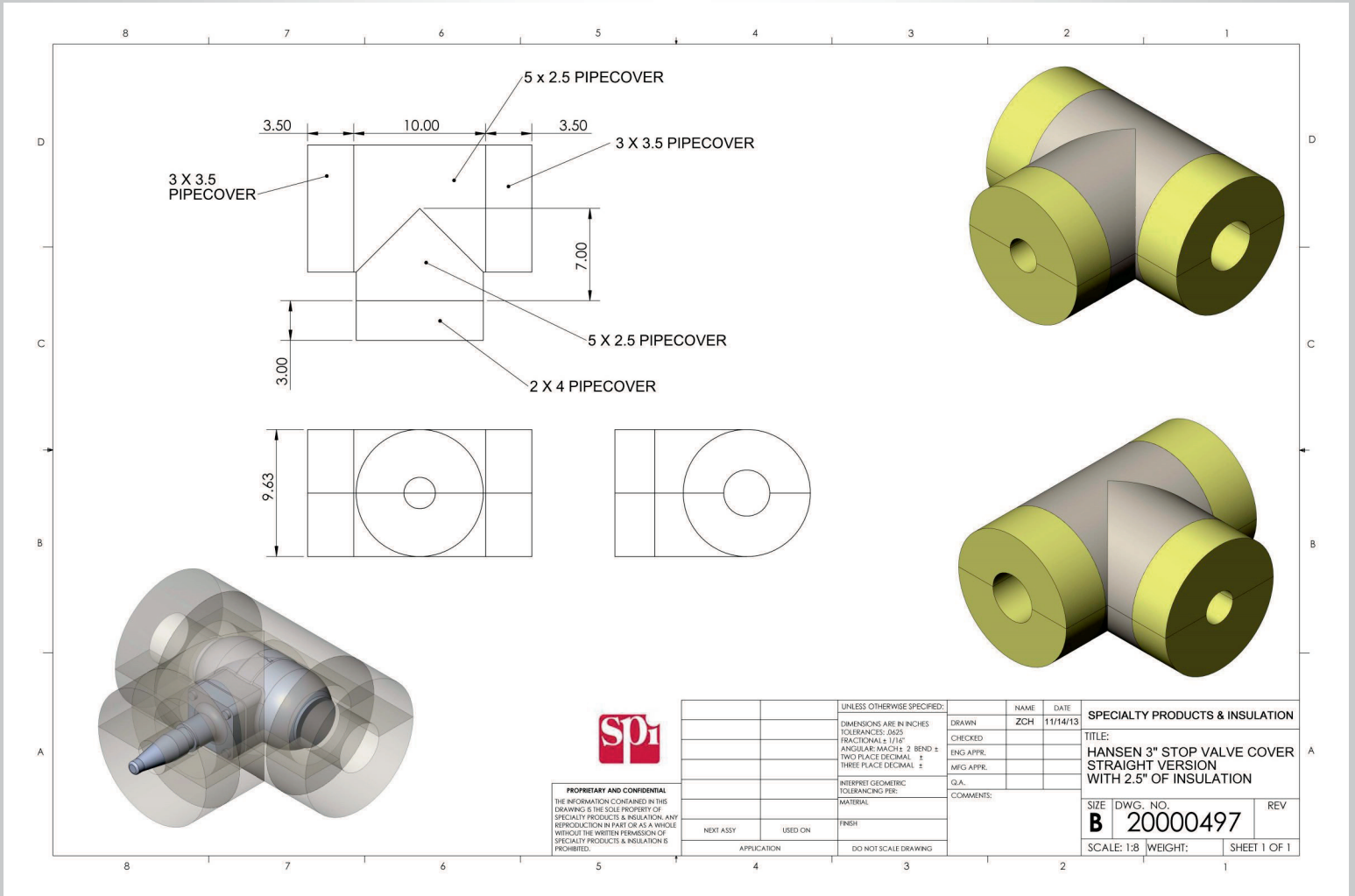

Concept to Design and Prototype to Production - The SPI team's expertise gets the job done.

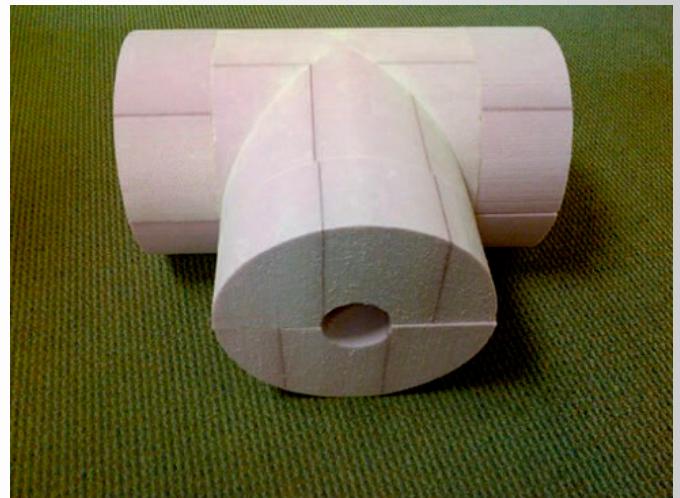
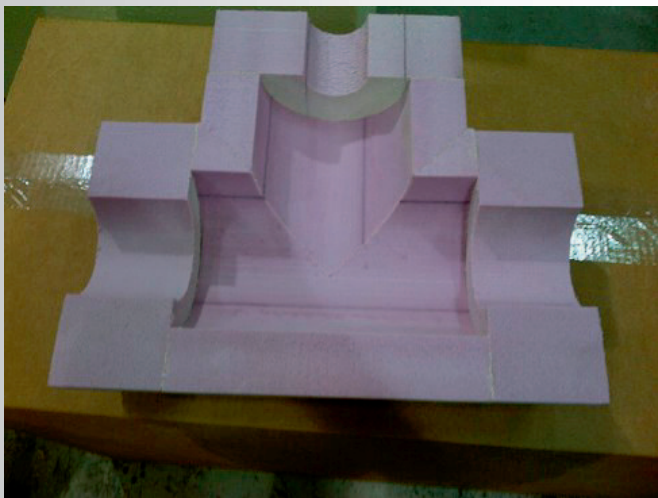

Jacketing and Cladding Materials - We supply of Aluminum, Stainless and Galvanized Steel in roll, sheet, stamped profiles and banding in the grade and gage required. We fabricate fitting covers and vessel jacketing in painted and corrosion inhibiting aluminum (smooth & embossed) and stainless steel. We provide metal lath, mesh and cut and curled PVC pipe and fitting covers along with labels for easy system identification.

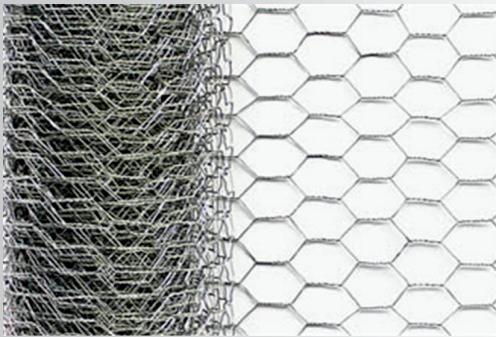
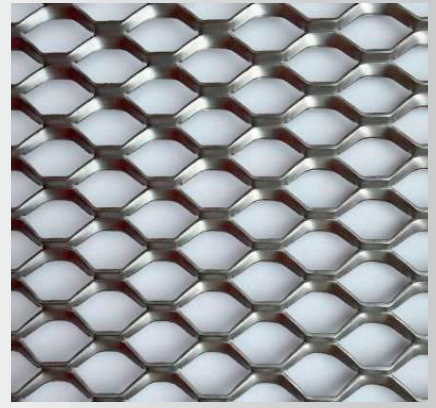
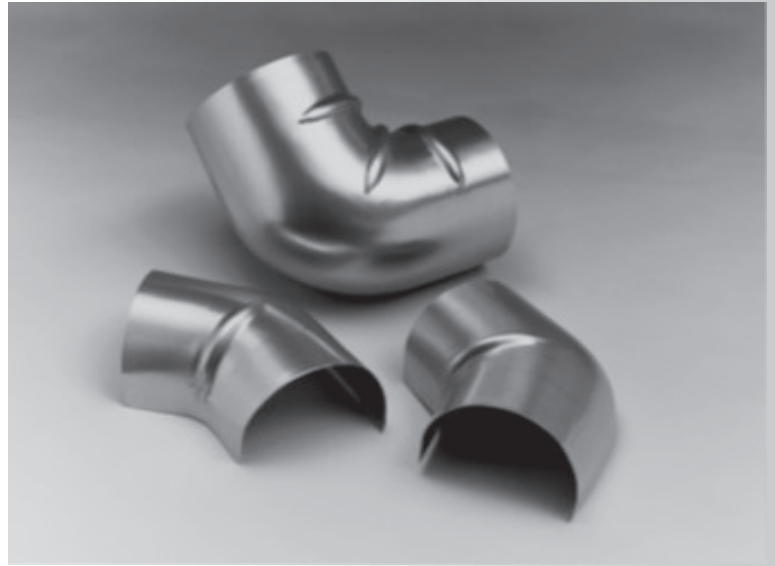

Fire Protection Products - Providing systems from leading manufacturers of Firestop systems for Penetrations and Joints, rated enclosures for Kitchen Exhaust, Clothes Dryer and Fume Exhaust Duct, Return Air Plenum protection systems, Curtain Wall Systems, Patented SafeLite® Fixture covers, Cable Raceway and Conduit, Structural steel and Vessel Fire Protection. Systems are evaluated to ASTM or UL fire standards. The range of products include: elastomeric sealants, spray coatings, intumescent caulks, putty, pillows and devices, fire resistant block, board, blanket, batt, mat and fire resistant coatings to treat wood and other combustibles.

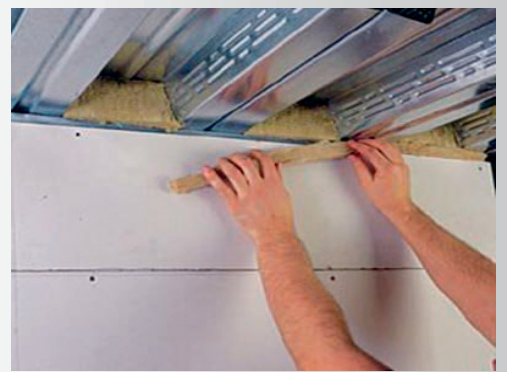
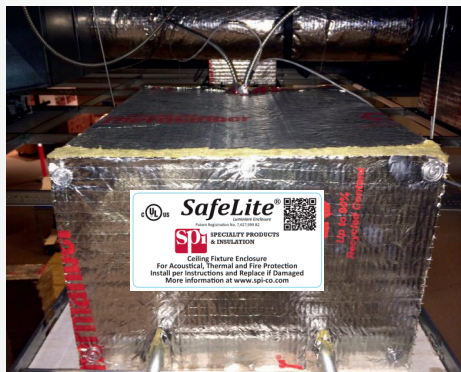
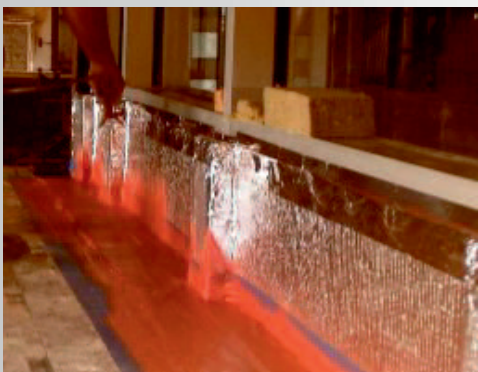

Acoustical Products & Services - We supply and custom fabricate sound absorbing and blocking materials as well as specialty composites using materials from leading manufacturers. Products provide acoustic solutions to address problems for Mechanical Systems, Building, Marine and OEM applications.

- Absorption Plus® Acoustic Wall, Cloud / Deck, Impact / Tack, Imagine (digital imaged), Baffle, Tack Panels and Diffusers.
- Composite absorber and barrier products
- SafeLite® sound blocking ceiling fixture covers
- Mass vinyl sound barrier
- Acoustic Fiberglass and Mineral wool
- Acoustic foam materials
- Sound Sealant and putty pads

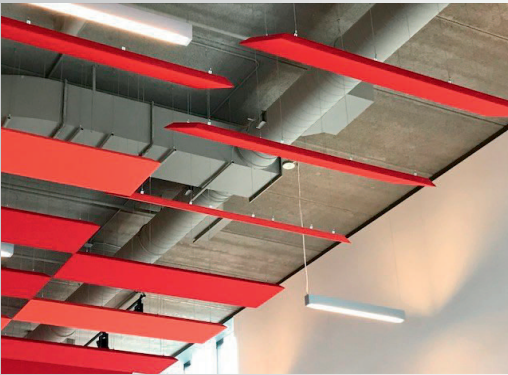
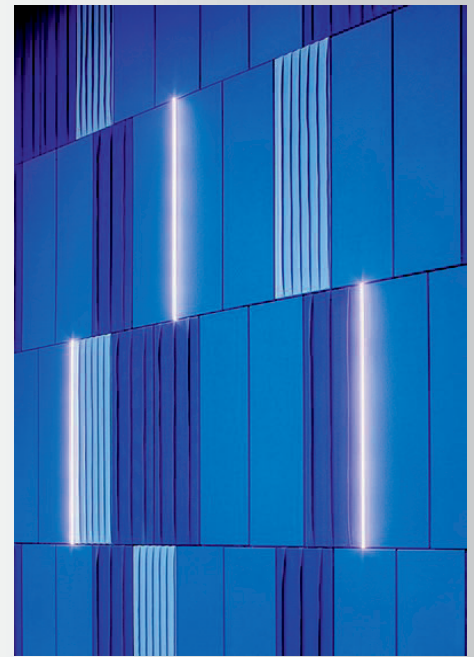

Refractory Products - Materials from leading manufacturers support application temperatures in excess of 3000°F. Products include: Bulk, Blanket, Board, V/F Shapes, Paper, Felt, Modules, Dense and Insulating Firebrick, Monolithics (Castable, Gunitite and Ramming Mix), Structural Block, Wet Products (felt, moldable, mastics, coatings & cement), Textiles, Rope, Gasket, Thread and Hardware. We provide custom slitting, cut to size, machined shapes, specialty laminations and composites to serve Industrial, Marine and OEM applications.

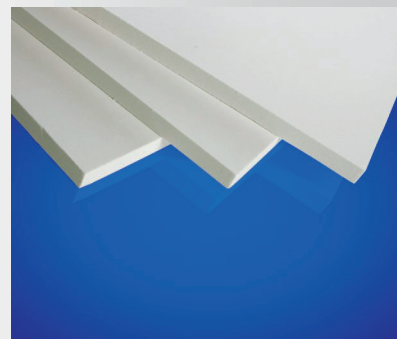

Building Insulation - Supplying a full range of insulation products from leading manufacturers of: fiberglass, mineral wool, extruded polystyrene and polyisocyanurate, spray foam (kits & drum) insulation and fabricated products and services for building envelope, parking garage and other applications.



Mastics, Coatings, Adhesives, Film, Tape, Fasteners - The quality products you need to prepare, install and finish the installation for optimal performance.



HVAC System Components - Spiral and snap lock pipe, stamped fittings (90's 45's, couplings and reducers), high efficiency take offs, air tight and bell-mouth collars, T's, endcaps, reducers, saddle taps, B-vent, 4 bolt flange systems (J&H), TDC/TDF components corners, cleat, slips & drive, turning vane and rail, flexible connector, damper hardware (dials, quadrants, end bearings, stand-offs and square rod), strut and threaded rod, weld pins, screws, wire rope hanging systems, sealant, caulk and adhesive, access doors, duct protection film, **Insulation:** duct liner, board, wrap, and flex duct.

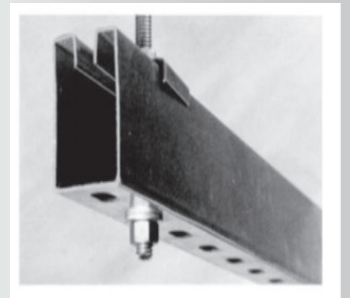
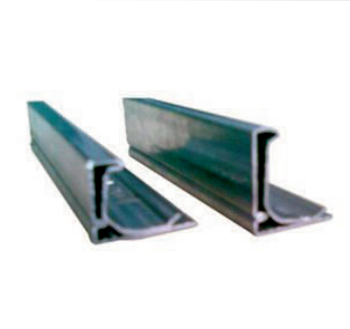
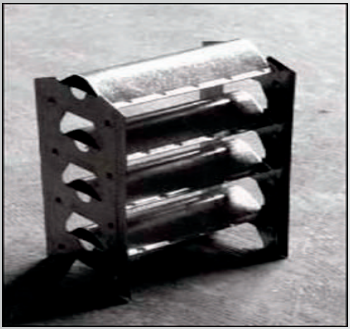

Specialty Lamination Services - Providing a wide range of lamination services for Commercial, Industrial, Marine and OEM applications. Many Commercial and Marine products are tested by accredited laboratories and applicable products are produced under lab follow-up service audits. Typical applications include: Deck and wall insulation systems for: metal buildings, parking garages, mechanical and electrical rooms, theaters, restaurants, performance space, etc.



Metal Building Insulation - SPI Distributes and fabricates MBI insulation and accessory products to suit project specific R Value and finish requirements.



PG Board TAF™ - Code requires parking garage and other unconditioned areas with adjacent occupied space to be insulated. Construction type and climate zone can require an R Values from 6.3 to R38. A single 8" layer of PG Board TAF has an R Value of 32.8 while the bright white, paper free, reinforced polypropylene, foil facing resists mold and mildew and provides 85% light reflectance. This brightens spaces to reduce lighting costs. An optional perforated facing provides enhanced sound absorption (NRC 0.70 at 4" thick).



Marine Products - SPI supplies a wide range of marine products and fabricate specialties for thermal, acoustic and fire protection applications. SPI's marine fabricated pipe, hull board and blanket products are produced under Coast Guard Certificates per IMO Standards. Ongoing Laboratory audits confirm consistent quality and specification compliance for:

- Pipe, duct, tank and equipment Insulation
- Hull, bulkhead, and deck insulation
- Sound absorber and blocking composites
- Recessed ceiling fixture covers with patented SafeLite®
- Firestop Systems (Image provided by STI Marine)
- Removable pad component materials and accessories
- Adhesives, mastics, and coatings
- Tape, mesh and fasteners

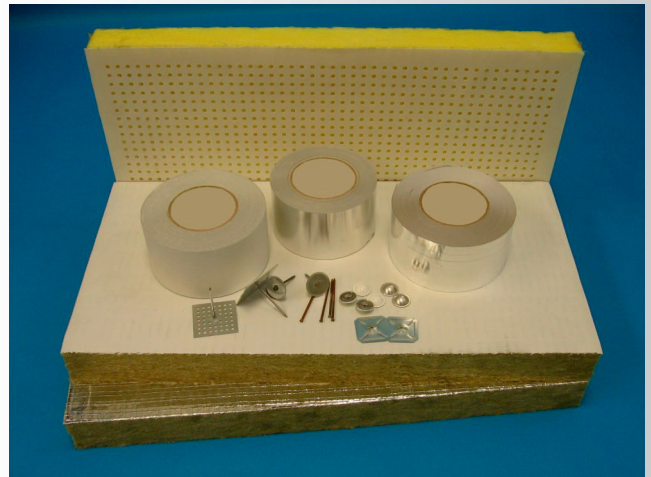
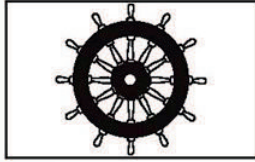

OEM Fabricated Products & Services - Specialized CNC saws, shapers, lamination equipment and more are used to fabricate precision components and insulation parts for applications from cold to high temperature, fire protection, condensation and noise control. Finished component materials can be used in a broad range of applications from appliances and HVAC equipment to RV's. We fabricate component parts to OEM specifications using materials from leading manufacturers.



Need help with a demanding project?

SPI's experienced team can assist with:

- Specification conformance review
- Product and application review
- Project priority planning and scheduling
- Bill of material review
- Submittal documentation
- Logistics coordination
- Order assembly, consolidation, packaging and specialty labeling
- Data Interface for accurate, timely material management
- Review material requirements for potential "value add" fabrication for site labor savings, etc.



Safety Supplies - SPI provides a complete range of personnel protective equipment from industry leading manufacturers so you can work safely.



Tools and Equipment - We provide industry related hand, power tools and equipment to safely and efficiently complete product installation and finishing.





Products including Insulation for Thermal, Acoustic and Fire Protection

ABATEMENT PRODUCTS

ABSORPTION PLUS® (ACOUSTIC PANELS)

ACOUSTICAL PRODUCTS

ADHESIVES & TAPES

ANTI-VIBRATION PADS

ATTACHMENTS (PINS, STUDS, STAPLES, ETC.)

BANDING & WING SEALS

BATT INSULATION

BUILDING INSULATION

CALCIUM SILICATE

CELLULAR GLASS

CEMENTS

CERAMIC FIBER CLOTH

COATINGS

CONSUMABLES (ALL TYPES)

CRYOGENIC WOOL

CURTAIN WALL INSULATION

DUCT INSULATION & FINISHES

ELASTOMERIC SHEETS AND ROLLS

ENCAPSULANTS & SURFACTANTS

EXPANDED PERLITE

FRP PANEL & ACCESSORIES

FRP/TRIM ADHESIVES

FABRICATION EQUIPMENT

FABRICATION SERVICES

- CELLULAR GLASS
- CURVED SIDEWALL SEGMENTS
- CUT & CLIP BANDING
- CUT & CURL PVC PRODUCTS
- CUT & ROLL METAL PRODUCTS
- DIE CUTTING
- DISHED HEADS
- INSULATION FITTINGS, VALVES,
- FLANGES (ALL TYPES)

- METAL FITTINGS, VALVES FLANGES (ALL)
- O.E.M PRODUCTS
- PHENOLIC FOAM
- PIPE & TANK WRAP
- PIPE COVERING (ALL TYPES)
- POLYISOCYANURATE
- POLYSTYRENE
- REMOVABLE/REPLACEABLE COVERS
- SLITTING
- URETHANE

FASTENERS

FIBERGLASS

FIRESTOP PRODUCTS

FIREPLUG®/FIRESTRIP®

FITTINGS (ALL TYPES)

HATS® (TANK HEAD SEGMENTS)

HAZMAT PRODUCTS

HEAD SEGMENTS

HVAC PRODUCTS & ACCESSORIES

- ACCESS DOORS
- B-VENT
- DAMPERS
- DIFFUSERS
- FLANGE
- NEOPRENE GASKETS
- REGISTERS
- SHEET METAL DUCT
- SPIRAL DUCT

JACKETING

LAGGING

MARINE HULL BOARD

MASTICS

MESH

METAL (All)

METAL BUILDING INSULATION (MBI)

MINERAL FIBER

MINERAL WOOL

NOISE ABATEMENT

PVC PRODUCTS

PANELS (ALL TYPES)

PHENOLIC FOAM

PIN WELDER REPAIRS, RENTAL & SALES

PIPE & TANK WRAP (RIGIDFLEX)

PIPE SADDLES & SHIELDS

PIPE SUPPORTS

PG BOARD TAF® (PARKING GARAGE BOARD)

PLASTIC JACKETING

POLYISOCYANURATE

POLYETHYLENE FILM

POLYSTYRENE

REFRACTORY PRODUCTS

REMOVABLE-REPLACEABLE COVERS (RIGID & FLEXIBLE)

RIGIDFLEX® (PIPE & TANK WRAP)

RUBBER PIPE, SHEETS & ROLL PRODUCTS

SAFELITE®

(CEILING FIXTURE COVER - FIRE, SOUND, ENERGY)

SAFETY PRODUCTS

SAFING INSULATION

SOUND PANELS

SUNDRIES

TAPES

TEXTILES (CLOTH & CANVAS)

TOOLS

URETHANE

VESSEL HEAD SEMENTS

WELDING BLANKETS

WIRE

These products are produced directly by SPI.

Distribution, Fabrication and Material Management

CONTINUOUS IMPROVEMENT PROCESS

CUSTOMIZED FABRICATION SOLUTIONS

DELIVERY SERVICE

ELECTRONIC DATA INTERCHANGE CAPABILITIES

ENERGY AUDITS (HEAT LOSS CALCULATIONS)

ESTIMATING (QUANTITY DEFINITION)

EXPORTING

SERVICES

GLOBAL SERVICE CENTER & ALLIANCE NETWORK

INDUSTRY EDUCATION SEMINARS

INTEGRATED SUPPLY AGREEMENTS

MATERIAL MANAGEMENT

MATERIAL WAREHOUSING & STORAGE

O.E.M. FABRICATION

PARTNERING

PROJECT/PLANT INVENTORY MANAGEMENT

SPECIFICATION DEVELOPMENT/REVIEW

STRATEGIC ALLIANCE AGREEMENTS

STATE OF THE ART TECHNOLOGY

& MANAGEMENT SYSTEMS

TECHNICAL PRODUCT INFORMATION

TRAINING (PRODUCTS & INSTALLATION)

NOV 2018

This list is representative of the range of products and services available from SPI's large network of distribution and fabrication facilities.

For product or service availability please contact your local SPI facility directly by visiting our location map at www.spi-co.com.

For technical support and questions please call 855-519-4044.

www.spi-co.com

Key vendor partnerships

We are proud of our long standing partnerships with these industry leading manufacturers.

These suppliers enable SPI to provide our customers consistent quality products in a timely fashion, at a competitive price.



Forrest Mfg. Co.



Talent | Technology | Trust™





Branch & Fabrication Network

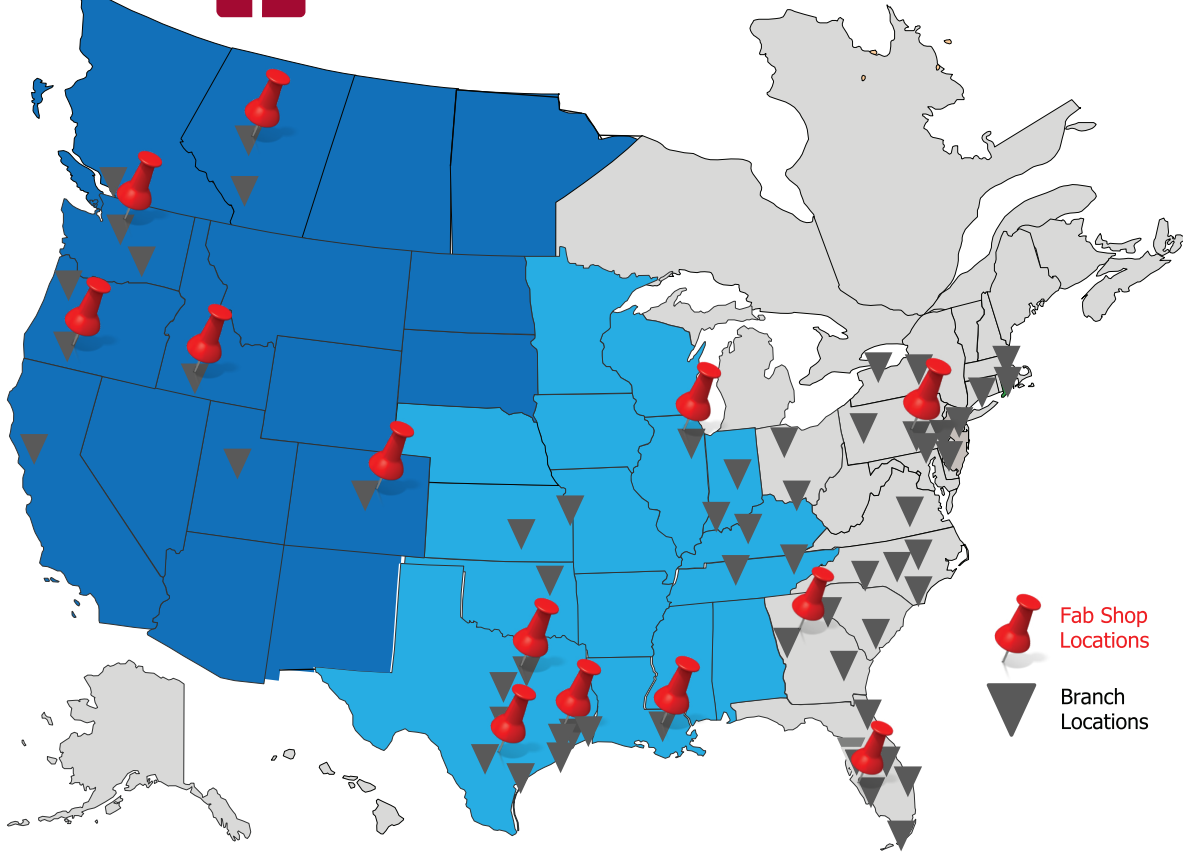

Branch Locations

Alexandria	VA	919-909-3540	Greensboro	NC	336-691-0008	Orlando	FL	407-826-1443
Auburn	MA	508-792-1133	Hanahan	SC	843-747-9713	Portland	OR	503-282-3275
Augusta	GA	706-722-2020	Houston	TX	713-861-3122	Raleigh	NC	919-828-7102
Austin	TX	512-326-3772	Indianapolis	IN	317-780-6135	Richwood	TX	979-266-8991
Baton Rouge	LA	225-379-5200	Itasca	IL	630-773-1200	Rochester	NY	585-328-2590
Beaumont	TX	409-347-8855	Jacksonville	FL	904-786-9800	Salt Lake City	UT	801-974-7684
Bellmawr	NJ	856-541-5806	Kennewick	WA	509-585-8885	San Antonio	TX	210-804-0119
Burnaby	BC	604-430-3044	Kingsport	TN	423-349-7799	Savannah	GA	912-233-5774
Calgary	AB	403-720-6255	La Porte	TX	713-673-6200	Seguin	TX	830-372-1500
Charlotte	NC	704-598-9899	Lake Bluff	IL	847-362-0925	Syracuse	NY	315-474-5190
Corpus Christi	TX	361-299-2221	Lancaster	PA	717-581-0650	Tampa	FL	813-621-5371
Decatur	GA	404-243-0670	Laurel	MD	240-294-6787	Tukwila	WA	253-872-0800
Denver	CO	303-333-6784	Louisville	KY	502-964-3127	Tulsa	OK	918-628-1010
Edmonton	AB	780-452-4966	McKees Rocks	PA	412-490-0601	Vacaville	CA	707-447-5401
El Dorado	KS	316-452-5652	Medford	OR	541-245-3284	West Haven	CT	203-375-6650
Endwell	NY	607-785-3577	Meridian	ID	208-887-9955	Wilmington	NC	910-799-8444
Evansville	IN	812-428-6388	Miami	FL	786-907-4022			
Fort Myers	FL	239-931-0364	Nashville	TN	615-227-8870			
Grand Prairie	TX	972-602-3555	N. Kansas City	MO	816-842-4900			

Fabrication Locations

Baton Rouge	LA	La Porte	TX	Seguin	TX
Decatur	GA	Lake Bluff	IL	Tampa	FL
Denver	CO	Lancaster	PA	Tukwila	WA
Edmonton	AB	Medford	OR		
Grand Prairie	TX	Meridian	ID		



SPI Distribution Center and Fabrication Facility, La Porte, TX - USA



SPI LLC - Specialty Products & Insulation

2101 Rexford Road, Suite 300E

Charlotte, NC 28211

Phone: (855) 519-4044

Web: www.spi-co.com

E-Mail: fabteam@spi-co.com

Primary Products & Services

- Mechanical Insulation
- Fabricated Specialties
- Jacketing & Cladding
- Fire Protection
- Refractory Products
- Acoustic Specialties
- Building Insulation
- HVAC Components
- Marine Insulation
- Safety Supplies
- Tools and Equipment